

GEM in-wheel drive

Synchronous GEM® in-wheel multiphase electric motor with permanent magnets and integrated controller.

Type G1.1

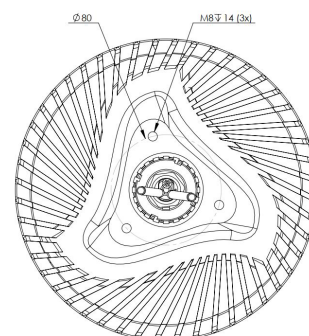
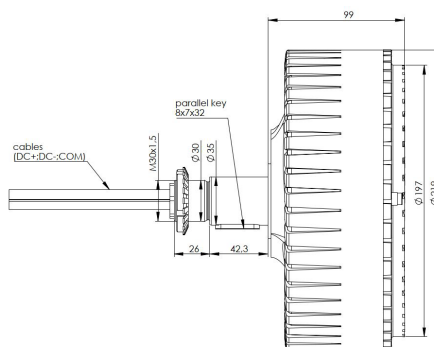

	0200	0350	Custom
Nominal power	1,3 kW	1,5 kW	1 ~ 2 kW
Nominal torque	80 Nm	65 Nm	50 ~ 100 Nm
Peak power (20 sec)	2,0 kW	2,3 kW	2 ~ 3 kW
Peak torque (20 sec)	110 Nm	90 Nm	80 ~ 120 Nm
Max. speed	350rpm at 48V DC	550rpm at 48V DC	150 ~ 800 rpm
Battery-to-wheel system efficiency	up to 91%		up to 94%
Voltage	48 V ~ 75 V max		24 V ~ 80 V
Wheel rim	Min size 10", integrated or external rim		Custom integrated, custom rim mounting
Mounting	One- or double-sided		Custom mounting
Cooling	Air		
Dimensions	Width 87 mm, diameter 219 mm		
Active motor weight	5 kg		
Total motor weight	8 kg		
Standard features	4Q operation, FOC speed and torque control, regenerative braking		
Motor controller	GEM modular type, integrated ®		
Signal interface	CAN 2.0 or analog		
IP Protection	IP 67		
Temperature range	- 40 ~ 60 °C		
Applications	Bike, light scooter, other 2-, 3- or 4-wheeler applications, farm or cargo vehicles, robotic vehicles		

For more information please contact us at sales@gemmotors.si or call +386 (0)59 023 893.