

GEM in-wheel drive

Synchronous GEM® in-wheel multiphase electric motor with permanent magnets and integrated controller.

Type G2.4

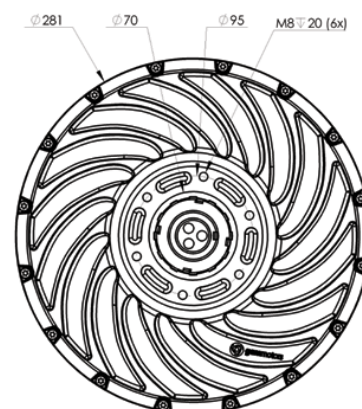
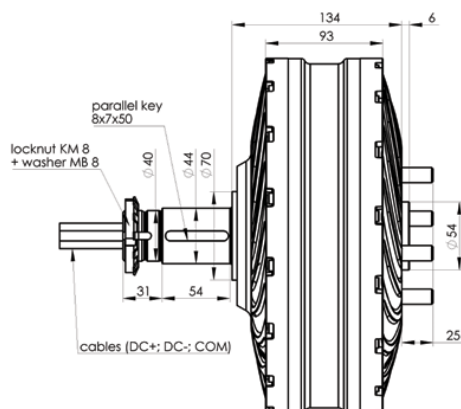

	0270	0500	Custom
Nominal power	4 kW	4 kW	3 ~ 5 kW
Nominal torque	180 Nm	140 Nm	100 ~ 190 Nm
Peak power (20 sec)	5 kW	6 kW	4 ~ 9 kW
Peak torque (20 sec)	240 Nm	180 Nm	150 ~ 250 Nm
Max. speed	450rpm at 48V DC	850rpm at 48V DC	300 ~ 1000 rpm
Battery-to-wheel system efficiency	up to 91%		up to 94%
Voltage	48 V ~ 75 V max		24 V ~ 80 V
Wheel rim	Min. size 13", integrated or external rim		Custom integrated, custom rim mounting
Mounting	One- or double-sided		Custom mounting
Cooling	Air		
Dimensions	Width 140 mm, diameter 281 mm		
Active motor weight	11,5 kg		
Total motor weight	19 kg		
Standard features	4Q operation, FOC speed and torque control, regenerative braking		
Motor controller	GEM modular type, integrated®		
Signal interface	CAN 2.0 or analog		
IP Protection	IP 67		
Temperature range	- 40 ~ 60 °C		
Certifications	IEC 60349-4:2012, ISO 10605, IEC 60034-5, ISO 9227-2006, ISO 16750-3, E/ECE Regulation No. 10, IEC 60068-2, MISRA C:2012		
Applications	e-scooter, motorbike, trike and 3-wheeler, micro car, golf cart, commercial or agriculture vehicle, robotic vehicles		

For more information please contact us at sales@gemmotors.si or call +386 (0)59 023 893.